

Modular Duct Heaters

Process Air Heaters Offer Improved Performance and Increased Power Versatility

Watlow's line of process air heaters offers improved performance and increased versatility in medium to low temperature applications.

The duct heaters are modular and consist of two parts. The first is a 6 kilowatt heater available in either 240 or 480 volts, single- or three-phase.

The second part of the heater consists of the electrical housing protecting each module's termination area and a main flange that bolts into the user's ductwork. The heater modules are installed in the housing and main flange via rectangular slots in the main flange. The range of modules that can be accommodated in various duct heater assemblies range from one to 10 modules. A range of 6 to 60 kilowatts, in 6 kilowatt increments is achieved.

The design of the modular duct heater offers increased reliability. The individual modules are removable through the housing of the assembly, which eliminates the need to pull the complete heater from the ductwork. This reduces downtime and costs because the heating elements can be replaced individually.

Performance improvements include quicker response time and reduced infiltration from the air stream being heated into the electrical enclosure.

Typical Applications

- Low temperature ovens
- Parts drying
- Semiconductor clean room environmental heating
- Plastic curing
- Load banks
- Heated air knives
- Food dehydration
- Heat shrink tunnels

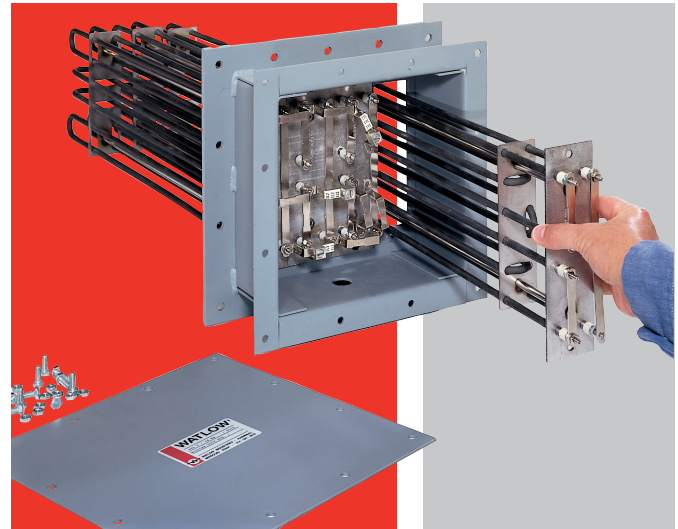

Features and Benefits

Individual modules are removable through housing

- Reduces downtime for replacement of the module

Smaller diameter elements (0.315 inch)

- Results in a 25 percent lower energy usage on the initial heat-up

27 percent reduction in heat-up time as compared to traditional 0.430 inch diameter duct heater elements

- Results in a faster response time

31 percent lighter weight than traditional tubular duct heaters

- Reduces shipping costs and increases worker safety

Greater free cross sectional area

- Results in lower pressure drop

Improved seal between the element and electrical housing

- Results in lower electrical housing temperature

Flexible module wiring

- Allows user to sequentially stage modules

Velocity vs. Process Temperature

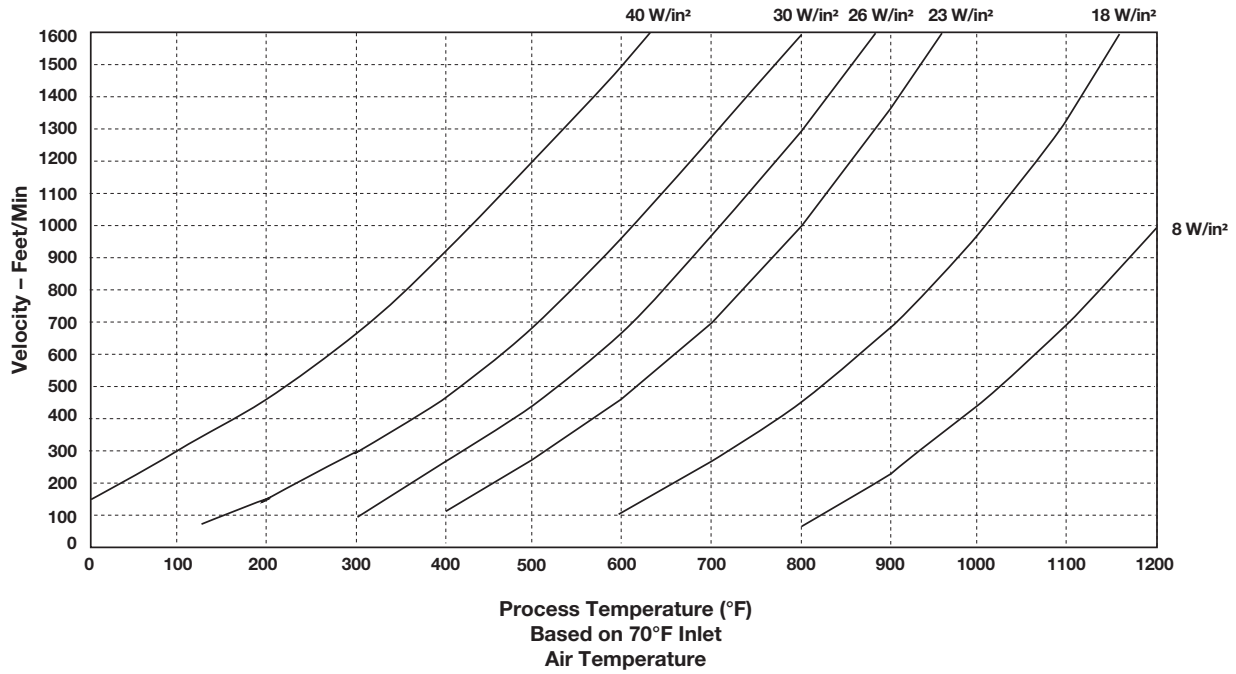

Watt Density vs. Sheath Temperature

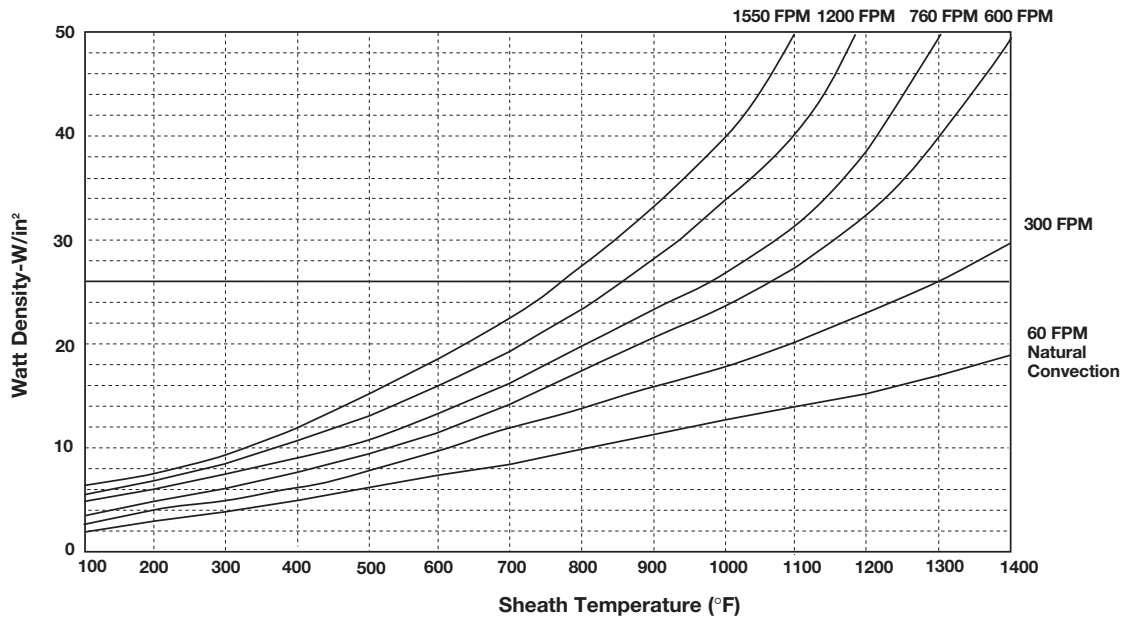

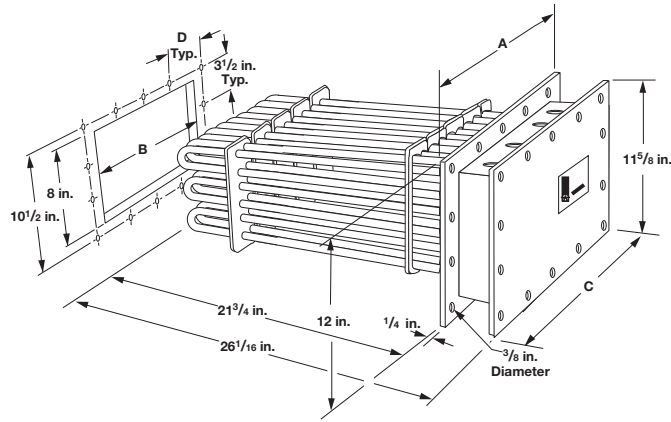

Application: Air Heating – Maximum outlet temperature – 750°F (399°C)

Watt Density W/in ²	kW	Volts	Phase	No. of Circuits	No. of Modules	Est. Shipping Wt. lbs	Del.	Part Number	Dimensions in.			
									A	B	C	D
26	6	240	1	1	1	35	M	MDH6SI0	6.50	2.50	5.75	2.50
26	6	240	3	1	1	35	M	MDH6S3	6.50	2.50	5.75	2.50
26	6	480	1	1	1	35	M	MDH6S11	6.50	2.50	5.75	2.50
26	6	480	3	1	1	35	M	MDH6S5	6.50	2.50	5.75	2.50
26	12	240	1	2	2	39	M	MDH12SI0	8.50	4.75	7.75	3.50
26	12	240	3	1	2	39	M	MDH12S3	8.50	4.75	7.75	3.50
26	12	480	1	1	2	39	M	MDH12S11	8.50	4.75	7.75	3.50
26	12	480	3	1	2	39	M	MDH12S5	8.50	4.75	7.75	3.50
26	18	240	1	3	3	46	M	MDH18SI0	10.50	7.00	9.75	3.00
26	18	240	3	1	3	46	M	MDH18S3	10.50	7.00	9.75	3.00
26	18	480	1	1	3	46	M	MDH18S11	10.50	7.00	9.75	3.00
26	18	480	3	1	3	46	M	MDH18S5	10.50	7.00	9.75	3.00
26	24	240	1	4	4	67	M	MDH24SI0	12.50	9.25	11.75	2.75
26	24	240	3	2	4	67	M	MDH24S3	12.50	9.25	11.75	2.75
26	24	480	1	2	4	67	M	MDH24S11	12.50	9.25	11.75	2.75
26	24	480	3	1	4	67	M	MDH24S5	12.50	9.25	11.75	2.75
26	30	240	3	2	5	84	M	MDH30S3	15.75	11.50	15.00	3.56
26	30	480	1	2	5	84	M	MDH30S11	15.75	11.50	15.00	3.56
26	30	480	3	1	5	84	M	MDH30S5	15.75	11.50	15.00	3.56
26	36	240	3	2	6	95	M	MDH36S3	18.00	13.75	17.25	4.13
26	36	480	1	2	6	95	M	MDH36S11	18.00	13.75	17.25	4.13
26	36	480	3	1	6	95	M	MDH36S5	18.00	13.75	17.25	4.13
26	42	240	3	3	7	109	M	MDH42S3	20.25	16.00	19.50	4.69
26	42	480	1	3	7	109	M	MDH42S11	20.25	16.00	19.50	4.69
26	42	480	3	2	7	109	M	MDH42S5	20.25	16.00	19.50	4.69
26	48	240	3	4	8	137	M	MDH48S3	22.50	18.25	21.75	5.25
26	48	480	1	3	8	137	M	MDH48S11	22.50	18.25	21.75	5.25
26	48	480	3	2	8	137	M	MDH48S5	22.50	18.25	21.75	5.25
26	54	240	3	3	9	144	M	MDH54S3	24.75	20.50	24.00	5.81
26	54	480	1	3	9	144	M	MDH54S11	24.75	20.50	24.00	5.81
26	54	480	3	2	9	144	M	MDH54S5	24.75	20.50	24.00	5.81
26	60	240	3	4	10	165	M	MDH60S3	27.00	22.75	26.25	6.38
26	60	480	1	4	10	165	M	MDH60S11	27.00	22.75	26.25	6.38
26	60	480	3	2	10	165	M	MDH60S5	27.00	22.75	26.25	6.38

• **M** - Manufacturing lead times

■ Truck Shipment only

Options include individual modules with optional general purpose housing, high-temperature thermocouple kit and blank flange modules.

Modular duct heaters with **1** and **2** modules have conduit openings for **one**, 1 inch NPT fitting.

Modular duct heaters with **3, 4, 5,** and **7** modules have conduit openings for **two**, 1 inch NPT fittings.

Modular duct heaters with **6, 8, 9,** and **10** modules have conduit openings for **two**, 1 1/4 inch NPT and **two**, 1 inch NPT fittings.

Specifications

- Module rating - 240 or 480VAC, 6kW, three-phase or one-phase
- Watt density - 26 W/in²
- Elements - 0.315 inch dia. alloy 840 elements
- High-limit thermocouple installed by drilling premarked hole in flange
- 6-60kW range when mounted in duct heater assembly

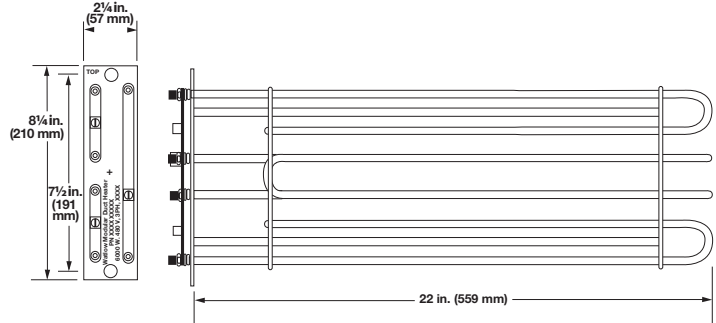

Application Information

- Maximum sheath temperature = 1200°F (649°C)
- Maximum outlet temperature = 750°F (399°C)

Options

Terminal Enclosures

Terminal enclosures are available in general purpose and moisture resistant configurations.

High-Limit Thermocouples

High-limit thermocouples can be supplied on specified modules or shipped as a kit. Available thermocouples are Types J and K.

Blank Module Covers

Module covers are available for covering blank slots on the main flange. This allows for adding heater modules at a later time to allow higher wattage outputs.

Watlow Part Number	Description
Replacement Modules	
M63	6kW, 240V, 3 phase
M610	6kW, 240V, 1 phase
M65	6kW, 480V, 3 phase
M611	6kW, 480V, 1 phase
High Limit Thermocouple Kits	
MTCJ	Type J (0-1000°F)
MTCK	Type K (0-2000°F)
Blank Module Covers	
MBLK	Cover slots in main flange

Watlow® is a registered trademark of Watlow Electric Manufacturing Company.

To be automatically connected to the nearest North American Technical Sales Office:

1-800-WATLOW2 • www.watlow.com • inquiry@watlow.com

International Technical Sales Offices: Australia, +61 3 9335 6449 • China, +86 21 3532 8532 • France, +33 1 41 32 79 70
 Germany, +49 (0) 72 53 / 94 00-0 • India, +91 40 6661 2700 • Italy, +39 024588841 • Japan, +81 3 3518 6630 • Korea, +82 2 2628 5770
 Malaysia, +60 3 8076 8745 • Mexico, +52 442 217 6235 • Singapore, +65 6773 9488 • Spain, +34 91 675 12 92
 Taiwan, +886 7 288 5168 • United Kingdom, +44 (0) 115 964 0777