

22 Series Valves

UHP Fluoropolymer Valves
1/2" and 3/4"

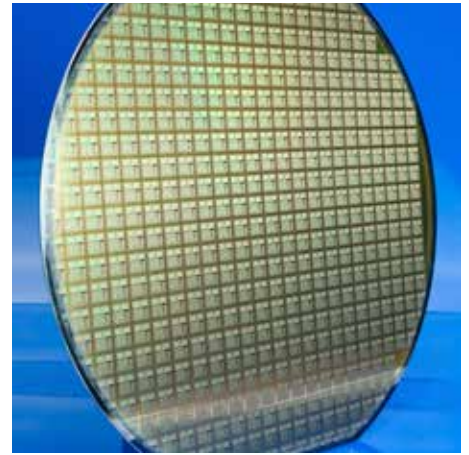

New! Ultra High Purity Fluoropolymer Valves

These new ultra clean valves offer increased flow and provide better seat sealing for enhanced leak-free performance and greater safety. They are designed to deliver the highest flow in the smallest package available.

CFD software was utilized to maximize the flow through these valves. The 22 Series Valve is best suited for UHP chemicals, acids, plating, and slurry chemicals.



Contact Information:

Parker Hannifin Corporation
Veriflo Division
250 Canal Blvd
Richmond, California 94804

phone 510 235 9590
fax 510 232 7396
veriflo.sales@parker.com

www.parker.com/veriflo
Mobile App: m.parker.com/veriflo

Product Features:

- Delivers high cycle life in acids and slurry with reduced maintenance
- Compact footprint
- Manual valve comes with a true lock-out, tag-out design
- Optimized slurry design for maximum cycle life
- Dual point seal for slurry (patent pending)
- Smooth bore, and fully swept path minimize particle entrapment areas
- High flow in small package
- 100% leak tested
- Meets SEMI-F57-0301 standards



ENGINEERING YOUR SUCCESS.

22 Series Valves 1/2" and 3/4"

Dimensional Drawings

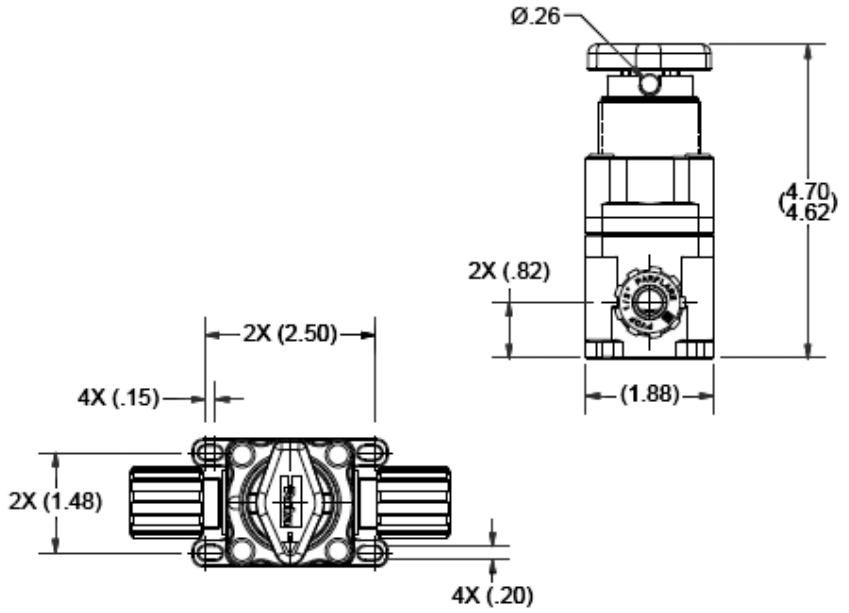
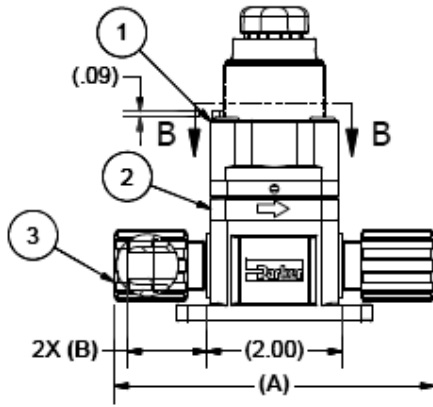

Connection	A	B
1/2" Flare	4.72	1.17
3/4" Flare	4.9	1.08

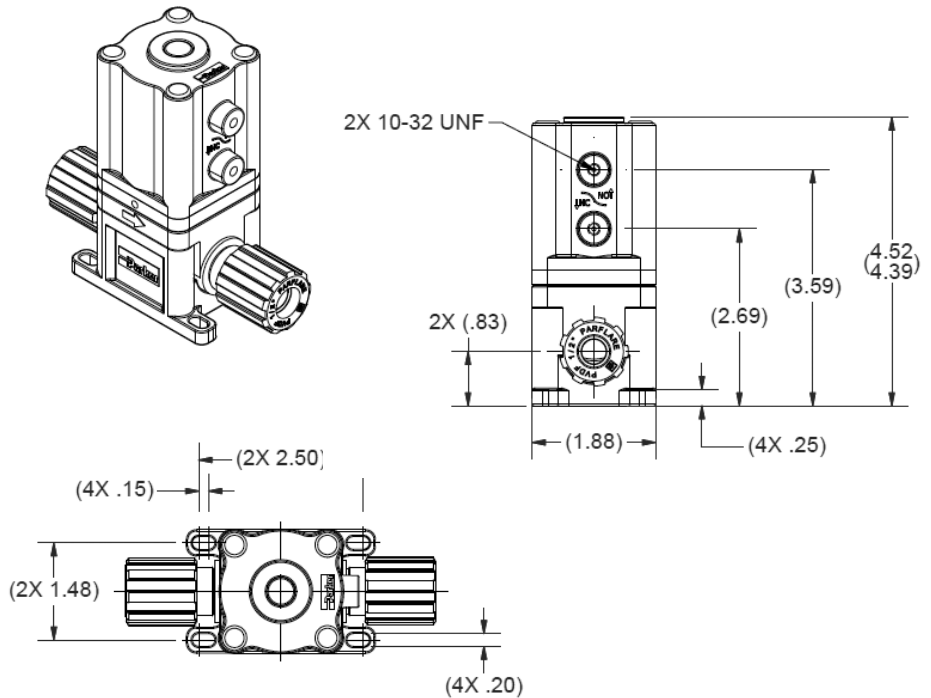
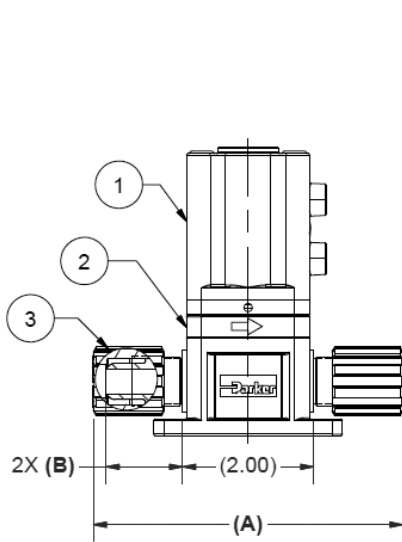













VIEW B

22 Series Valves 1/2" and 3/4"

Ordering Information

Build a 22 Series valve by replacing the numbered symbols with an option from the corresponding tables below.

Sample:  **PV22**  **08**  **V**  **N**  **I**  **FL**  **08**  **FL**  **08**  **V** 

 **1 Base Model**
 PV22 = Pneumatic valve
 MV22 = Manual valve

 **2 Valve Size**
 08 = 1/2"

 **3 Valve Trim Material**
 V = PVDF
 PolyVinylidene-Fluoride

 **4 Valve Housing Actuator Style**
 N = Standard,
 specific to each valve size
 P = Pipe 1/8-27 FNPT,
 specific to each valve size

 **5 Valve Style**
 0 = 2-way manual valve
 1 = Normally Closed
 2 = Normally Open

 **6 Inlet End Style**
 FL = Panflare

 **7 Inlet End Size**
 08 = 1/2"

 **8 Outlet End Style**
 FL = Panflare

 **9 Outlet End Size**
 08 = 1/2"

 **10 Nut Type**
 V = PVDF
 T = PFA

 **11 Specials**

**Panel mount nut sold separately
 PN-2208 = 1/2" 22 series panel
 mount nut*

Part Number	Nominal Valve Size	Valve Trim Material	Actuator Connection	Valve Type	Inlet End Style	Inlet Size	Outlet End Style	Outlet End Size	Nut Type
PV2208VN1FL08FL08T	1/2"	PVDF	10-32	Normally Closed	Flare	1/2"	Flare	1/2"	PFA
PV2208VN1FL08FL08V	1/2"	PVDF	10-32	Normally Closed	Flare	1/2"	Flare	1/2"	PVDF
PV2208VN1FL12FL12T	1/2"	PVDF	10-32	Normally Closed	Flare	3/4"	Flare	3/4"	PFA
PV2208VN1FL12FL12V	1/2"	PVDF	10-32	Normally Closed	Flare	3/4"	Flare	3/4"	PVDF
PV2208VN2FL08FL08T	1/2"	PVDF	10-32	Normally Open	Flare	1/2"	Flare	1/2"	PFA
PV2208VN2FL08FL08V	1/2"	PVDF	10-32	Normally Open	Flare	1/2"	Flare	1/2"	PVDF
PV2208VN2FL12FL12T	1/2"	PVDF	10-32	Normally Open	Flare	3/4"	Flare	3/4"	PFA
PV2208VN2FL12FL06V	1/2"	PVDF	10-32	Normally Open	Flare	3/4"	Flare	3/4"	PVDF

22 Series Valves 1/2" and 3/4"

Specifications

Materials of Construction	
Wetted	
Body	PFA
Diaphragm	Modified PTFE
Non-wetted	
Housing, Lever	PVDF
Spring	SS, Fluoropolymer coated
Screws	SS
Operating Conditions (Operating limits based upon pressure applied at inlet port.)	
Maximum Pressure	80 psig
Minimum Pressure	Vacuum
Actuation Pressure	60 to 100 psig
Media Temperature	0° to 100°C / 32° to 212°F
Storage Temperature	-40° to 65°C / -40° to 150°F
Environment Temp	0°F to 120 °F

Functional Performance	
Proof Pressure	120 psig
Burst Pressure	200 psig
Flow Capacity	
1/2" Flare	2.3
3/4" Flare	4.3
Leak Rate	
Internal	No bubbles 30 sec, N2 gas
External	Bubble tight

OFFER OF SALE:

The items described in this document are hereby offered for sale by Parker-Hannifin Corporation, its subsidiaries or its authorized distributors. This offer and its acceptance are governed by the provisions stated in the detailed "Offer of Sale" elsewhere in this document or available at www.parker.com/veriflo

WARNING USER RESPONSIBILITY

FAILURE OR IMPROPER SELECTION OR IMPROPER USE OF THE PRODUCTS DESCRIBED HEREIN OR RELATED ITEMS CAN CAUSE DEATH, PERSONAL INJURY AND PROPERTY DAMAGE. THIS DOCUMENT IS FOR REFERENCE ONLY. PLEASE CONSULT FACTORY FOR LATEST PRODUCT DRAWINGS AND SPECIFICATIONS

This document and other information from Parker-Hannifin Corporation, its subsidiaries and authorized distributors provide product or system options for further investigation by users having technical expertise.

The user, through its own analysis and testing, is solely responsible for making the final selection of the system and components and assuring that all performance, endurance, maintenance, safety and warning requirements of the application are met. The user must analyze all aspects of the application, follow applicable industry standards, and follow the information concerning the product in the current product catalog and in any other materials provided from Parker or its subsidiaries or authorized distributors.

To the extent that Parker or its subsidiaries or authorized distributors provide component or system options based upon data or specifications provided by the user, the user is responsible for determining that such data and specifications are suitable and sufficient for all applications and reasonably foreseeable uses of the components or systems.

The products described herein, including without limitation, product features, specifications, designs, availability and pricing are subject to change by Parker Hannifin Corp and its subsidiaries at any time without notice.

Proposition 65 Warning: This product contains chemicals known to the state of California to cause cancer or birth defects or other reproductive harm.

