

TYPE GUX EXPLOSION PROOF UNIT HEATERS

APPLICATIONS

Explosion proof unit heaters are designed to heat areas classified as hazardous locations designated as Class I, Group C & D or Class II, Groups E, F, and G, Divisions 1 & 2, with a T3B ignition temperature code rating (329°F, 165°C) to provide primary or supplementary heating for comfort or freeze protection. Typical applications involve oil refineries, sewage treatment plants, petrochemical plants, oil rigs, unattended pumping stations, chemical storage and handling facilities, paint storage areas, and countless other hazardous areas covered by these classifications.

CONTROLS — Prewired, self-contained control center. Standard controls include automatic reset thermal limit, a magnetic contactor, and 24 volt control circuit transformer.

HEAT EXCHANGER — Advanced design allows lower operating temperatures from the liquid to air heat exchanger with steel tubes, aluminum fins, a non-toxic heat transfer fluid, and a pressure relief plug.

OPTIONAL CONTROLS — Includes a factory built-in thermostat, disconnect switch, fan selector switch, 120V control circuit, and pilot light.

HIGH LIMIT CUTOUTS— An manual reset high limit cutout unit is standard. (An additional auto-

matic reset high limit cutout is available as an option.)

FAN & MOTOR — Ball bearing permanently lubricated explosion proof motor has built-in thermal overload protection.

CABINET — Powder coated heavy gauge steel cabinet surrounding a 14 gauge heavy-duty steel frame which supports internal components.

SELECTION CHART

CATALOG NUMBER	HEATER VOLTS	WATTS (KW)	PHASE	CONTROL VOLTAGE*	OUTPUT BTU/HR.	TOTAL AMPS	VOLUME CFM	AIR TEMP RISE	THROW	WT. (lbs.)
GUX300812	208	3	1	24	10,236	16.7	700	13°F	28 ft.	133
GUX300832	208	3	3	24	10,236	9.7	700	13°F	28 ft.	133
GUX300412	240	3	1	24	10,236	14.8	700	13°F	28 ft.	133
GUX300432	240	3	3	24	10,236	8.6	700	13°F	28 ft.	133
GUX3004832	480	3	3	24	10,236	4.3	700	13°F	28 ft.	133
GUX300632	600	3	3	24	10,236	3.6	700	13°F	28 ft.	133
GUX500812	208	5	1	24	17,060	26.3	700	22°F	28 ft.	133
GUX500832	208	5	3	24	17,060	15.3	700	22°F	28 ft.	133
GUX500412	240	5	1	24	17,060	33.6	700	22°F	28 ft.	133
GUX500432	240	5	3	24	17,060	19.4	700	22°F	28 ft.	133
GUX5004832	480	5	3	24	17,060	9.7	700	22°F	28 ft.	133
GUX500632	600	5	3	24	17,060	8.1	700	22°F	28 ft.	133
GUX750812	208	7.5	1	24	25,590	38.4	840	27°F	28 ft.	133
GUX750832	208	7.5	3	24	25,590	22.2	840	27°F	28 ft.	133
GUX750412	240	7.5	1	24	25,590	33.6	840	27°F	28 ft.	133
GUX750432	240	7.5	3	24	25,590	19.4	840	27°F	28 ft.	133
GUX7504832	480	7.5	3	24	25,590	9.7	840	27°F	28 ft.	133
GUX750632	600	7.5	3	24	25,590	8.1	840	27°F	28 ft.	133
GUX1000832	208	10	3	24	34,120	29.2	840	36°F	32 ft.	138
GUX1000412	240	10	1	24	34,120	44.5	840	36°F	32 ft.	138
GUX1000432	240	10	3	24	34,120	25.5	840	36°F	32 ft.	138
GUX10004832	480	10	3	24	34,120	12.7	840	36°F	32 ft.	138
GUX1000632	600	10	3	24	34,120	10.6	840	36°F	32 ft.	138
GUX1500832	208	15	3	24	51,180	43.0	1450	31°F	47 ft.	158
GUX1500432	240	15	3	24	51,180	37.5	1450	31°F	47 ft.	158
GUX15004832	480	15	3	24	51,180	18.7	1450	31°F	47 ft.	158
GUX1500632	600	15	3	24	51,180	15.7	1450	31°F	47 ft.	158
GUX20004832	480	20	3	24	68,240	24.8	1400	43°F	43 ft.	169
GUX2000632	600	20	3	24	68,240	20.7	1400	43°F	43 ft.	169
GUX25004832	480	25	3	24	85,300	31.1	2330	32°F	54 ft.	214
GUX2500632	600	25	3	24	85,300	25.8	2330	32°F	54 ft.	214
GUX30004832	480	30	3	24	102,360	37.1	2330	39°F	54 ft.	214
GUX3000632	600	30	3	24	102,360	30.2	2330	39°F	54 ft.	214

*Note: Above models have built-in 24 volt control. Optional 120 volt control is available. Replace the "2" suffix with "1" for 120 volt control.

DIMENSIONS

UNIT SIZE	A		B		C		D		E	
	IN.	MM	IN.	MM	IN.	MM	IN.	MM	IN.	MM
3-10KW	19-1/8	486	23-7/8	606	21	533	3-1/5	89	13-5/8	346
15-20KW	25	635	27-7/8	708	21	533	4-13/32	112	17-5/8	448
25-30KW	32-1/8	816	31-7/8	810	21-3/4	552	5-1/2	140	21-5/8	549

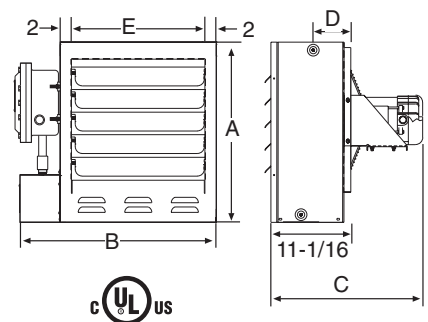

ACCESSORIES

CATALOG NUMBER	DESCRIPTION
GUXPM12	Pole Mounting Bracket for units 3KW thru 10KW.
GUXPM16	Pole Mounting Bracket for units 15KW thru 20KW.
GUXPM18	Pole Mounting Bracket for units 25KW thru 30KW.
GUXWM12	Wall Mounting Kit for units 3KW thru 10KW.
GUXWM16	Wall Mounting Kit for units 15KW thru 20KW.
GUXWM18	Wall Mounting Kit for units 25KW thru 30KW.
GUXCMO	Ceiling/Hang Mounting Kit for all Models.
JC80EP*	Wall Mounted Thermostat

Specify type of mounting bracket required at time of order entry.
*Approved for Class I, Group D and Class II Group E, F and G locations.